

6 a/b/c*

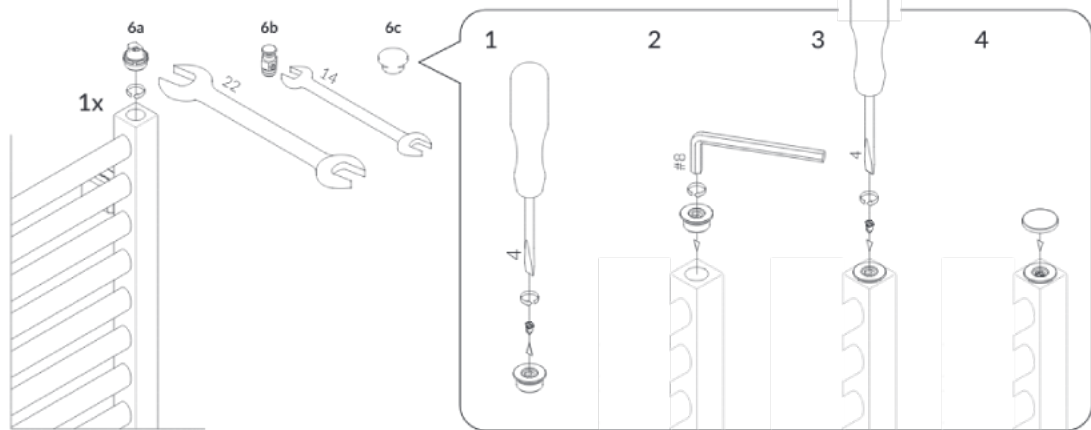

User Manual

Mounting bracket **MKP/MKS**
4x

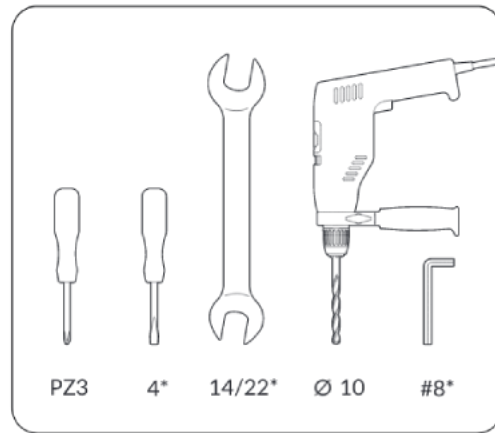
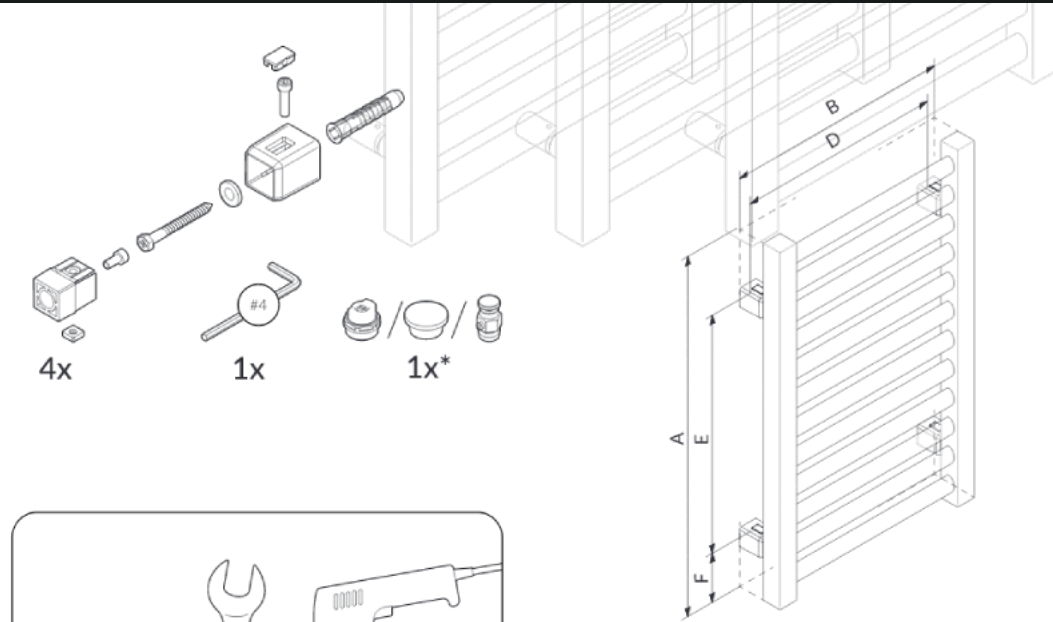

* Refers to water and dual fuel version

2

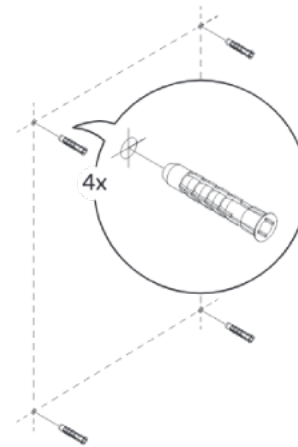

1

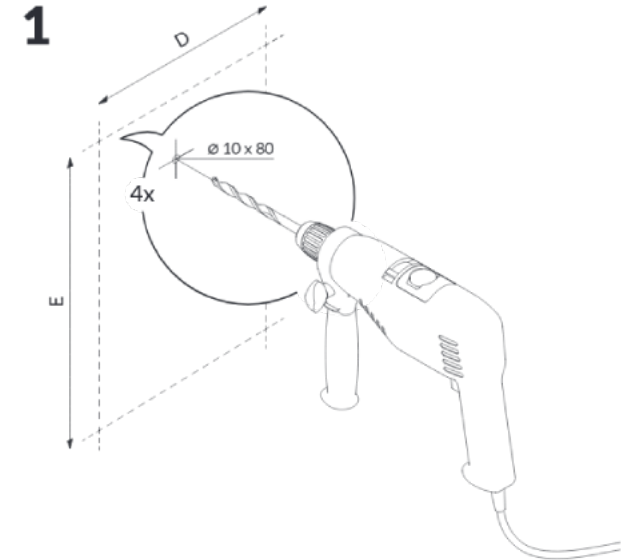

3

