

Outline installation & maintenance instructions

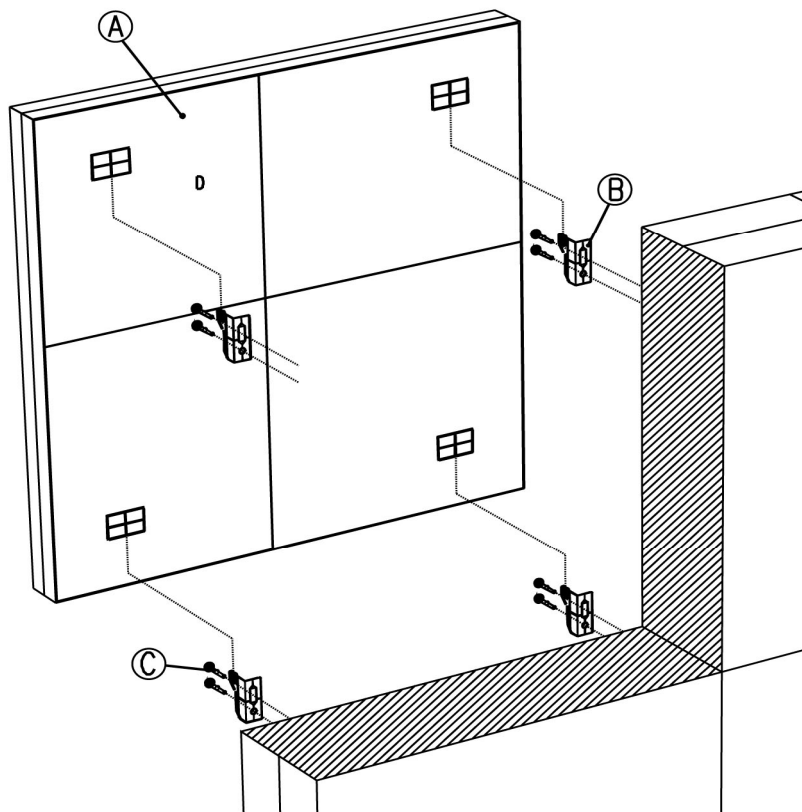

Key

Component	Qty
A Radiator	1
B Wall mounting brackets	4 as standard, 6 or 8 on larger radiators (these are attached to radiator manifold with ties for transit)
C Screws*	2 per bracket

* Screws and all plugs are not supplied with radiator. Screws must be selected according to wall material and construction, i.e. brickwork, plasterboard, wood panelling etc. The maximum design loading per fixing is 8kg.

Tools required

Valves (contact your distributor for valves aesthetically matched to radiator) Allen key or spanner to suit valves
 PTFE tape (high density tape is preferred)
 Tape measure
 Spirit Level
 Electric Drill Masonry drill bit to suit wall plug or screw size (Eskimo brackets will take screws up to 7mm in diameter)
 Screws & Wall plugs as required
 Screwdriver
 Bleed Key

****Gong radiators – Eskimo supplies cotton jeweller's gloves with these finishes; please ensure our installer wears these at all times to avoid unnecessary cleaning after installation**

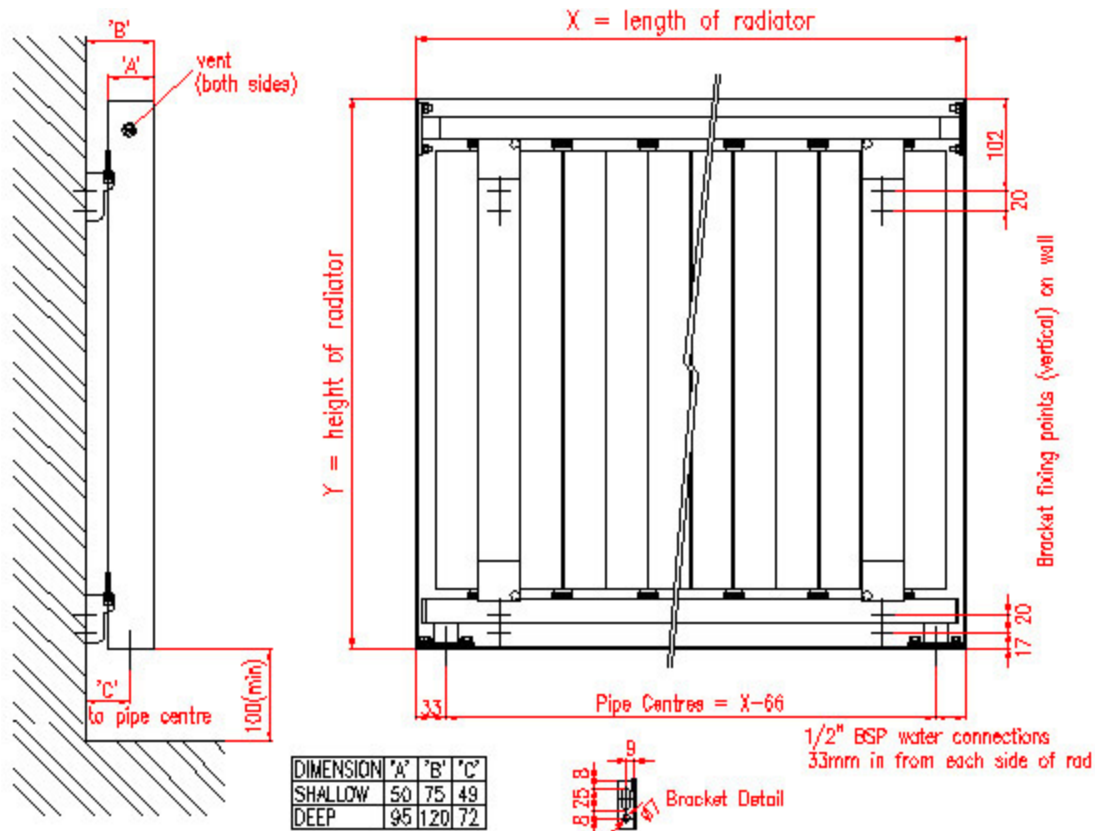

- Before starting work, ensure working area is free of obstructions and objects that could cause harm to you or the radiator. Unpack radiator carefully but **do not fully remove protective plastic film until installation is complete, if necessary unpeel film to check for transit damage then replace.** If laying the radiator onto the floor, place it with the back (aluminium heat exchanger) face to the floor, unless you can ensure that there is nothing underneath that could cause damage to the flat panel face – grit or foreign objects can scratch the flat panel through the protective film.
- Apply sufficient PTFE tape to valve tail threads to provide a leak-tight seal.
- Screw valve tails into threaded pipe connections on radiators **please note, the female aluminium threads in the radiator can be damaged by cross-threading of the valve tails – ensure that thread is correctly aligned before tightening.** Do not over-tighten.
- Measure horizontal bracket positions on back of radiator, vertical positions are shown on drawing above. Refer this to bracket mounting holes and accurately mark out hole positions on wall using a spirit level and tape measure.
- Drill holes *for slotted bracket hole only* in wall as required by screws and wall plugs used.
- Attach brackets (B) to wall initially with one screw only through slotted hole ensuring the hook is at the top.
- Check brackets for alignment using spirit level, and adjust as necessary, then drill and screw second bracket hole. **It is essential that all brackets align correctly with their corresponding mounting positions on the radiator – the radiator must not be forced onto misaligned brackets or damage may occur causing the radiator to leak.**
- Hang the radiator onto the brackets ensuring all brackets are fully engaged. **Radiators are a heavy item, and many of the radiators in our range require more than 1 person to lift them safely. Never attempt to mount a radiator that you cannot comfortably lift.**
- System design, flushing and dosing must be in accordance with BS5449: 1990, BSEN12828, 2003 and BS7593:1992., paying particular attention to the flushing of the system and the dosing of the system with a corrosion inhibitor compatible with aluminium – Eskimo recommend Fernox F1, formulated for mixed metal systems. **Remove protective plastic film before subjecting radiator to heat.**
- If installation problems arise, please refer to the Eskimo website for more detailed information, specifically on the correct venting and system balancing procedure. If problems persist, please contact the Eskimo technical department – the number is shown at the top of this page.
- Brushed stainless steel can be cleaned with baby oil, mirror stainless steel with a glass mirror cleaner. **Abrasive cleaners should never be used on Eskimo products.**